

DRAWING FOR REFERENCE ONLY

≥15.88 mm
(0.625")

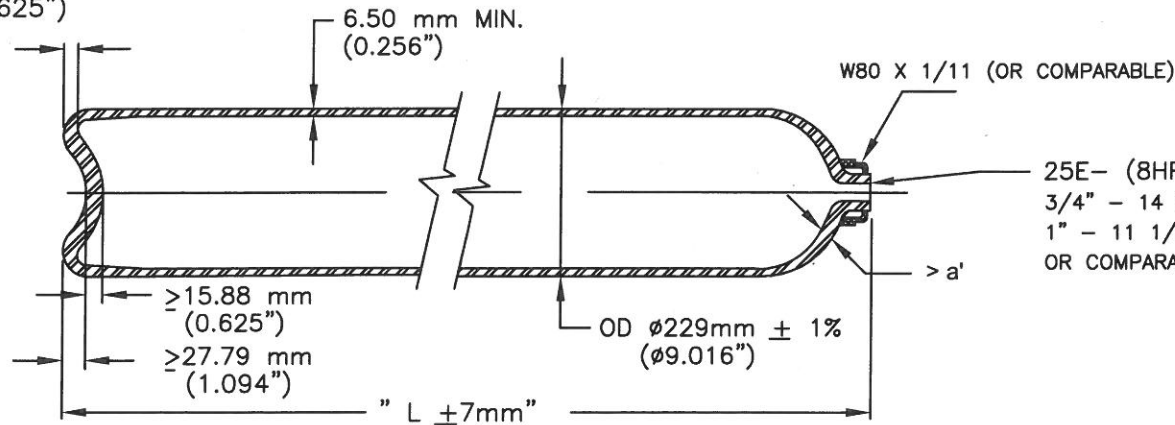

REV.	ECN - DESCRIPT.	DATE	DRWN.	CHKD.	APP.
06	2985	9/14/10	JJM		

25E- (8HP504C-25E),
3/4" - 14 NGT (8HP504C-3),
1" - 11 1/2 NGT (8HP504C-1),
OR COMPARABLE

SPECIFICATION: ISO 9809-2: 2000

1. Service Conditions:

(1 bar = 14.5 psi)

- Working pressure: 300 bar (4351 psi)
- Hydraulic test pressure: 450 bar (6527 psi)

2. Material:

Cr-Mo-steel complying with the requirements of clause 6.2 of ISO 9809-2. Norris' 4133M4, per EO-A6, is a currently qualified steel.

3. Manufacture:

Hot billet extrusion followed by hot drawing

4. Heat Treatment: Quenched and Tempered

- Austenitize: ~899°C (1650°F)
- Quenchant: Water based polymer (temperature ≤ 60°C(140°F))
- Temper: >573°C (1065°F) (Min. 30 minutes at temp.)

5. Mechanical Properties: (at room temperature)

- Tensile (Rg): 1100 - 1220 MPa (159.6 - 177 ksi)
- Yield (Re): ≥ 935 MPa (135.6 ksi)
- Elong (A): ≥ 12% (ON 5.65 √S₀)

5. Mechanical Properties continued:

- Out-of-roundness, Straightness, and Verticality per ISO 9809-2 sections 8.5- <2%, 8.7- <3 mm/m, and 8.8- <10 mm/m.
- Hydraulic and volumetric expansion test per 11.2 of ISO 9809-2.
- Hardness test: Each end of every cylinder
4133M4: HB315-370
- Flattening test: Flatten to 10 x t_m without cracks
- Charpy test (-50°C, Trans): ≥ 35 J/cm² (avg.)
(4133M4 Approved B for 5-7.5mm: 56.8 J/cm²)
- UT flaw detection: Each cyld. per ISO 9809-2.
- Batch burst test: Pb ≥ 720 bar (10,443 psi)

6(a). Thickness Calculations: (ISO 9809-2: 2000)

$$a = 0.5xD \left(1 - \sqrt{\frac{(10FRe - \sqrt{3} Ph)}{(10FRe)}} \right)$$

Where:

- Ph = Test Pressure (bar) = 450 bar (6527psi)
- D = External diameter of container = 231.3mm Max
- F = Lesser of 0.65/(Re/Rg) or 0.85; Re/Rg ≤ 0.9
- = Lesser of 0.65/0.85 or 0.85 = 0.765 (for Re/Rg = 0.85)

$$a = 0.5 \times 231.3 \left(1 - \sqrt{\frac{(10 \times 0.765 \times 935 - \sqrt{3} \times 450)}{(10 \times 0.765 \times 935)}} \right) = 6.48 \text{ mm (0.255")}$$

NOTE: a', the guaranteed min thickness = 6.50 mm (0.256") exceeds calculated min thickness, a.

MODEL	LENGTH 'L'		Min WATER CAPACITY		APPROX. WGT. W/O FITTINGS	
	MM	IN	LITERS	IN ³	KG	LBS
8HP320C	965	38.0	30.0	1831	46.3	102
8HP426C	1270	50.0	40.0	2441	60.8	134
8HP495C	1422	56.0	46.3	2825	67.2	148
8HP504C	1448	57.0	47.2	2880	68.5	151
8HP506C	1480	58.26	48.5	2960	69.0	152
8HP530C	1519	59.8	50.0	3051	71.7	158
*Vmin	698	27.5	20.2	1233	37.2	82
*Vmax	2121	83.5	72.1	4404	98.0	216

*Note: Model 8HP504C was the qualification cylinder for 4133M4 steel. Vmin and Vmax represent the range covered by the same design family. For max ovality, max verticality deviation, and max Straightness deviation see Norris document: 363-00



NORRIS CYLINDER COMPANY
4818 WEST LOOP 281 LONGVIEW, TEXAS 75603 USA

REFILLABLE SEAMLESS STEEL CYLINDER
FOR PERMANENT GASES EXCEPT
EMBRITTLING GASES PER ISO 11114-1

SCALE	NOT TO SCALE	DRAWING NO.		REV.
DWN. BY	JJM	10/28/08	901A-A-9756	06
CHK'D BY				
APP'D BY		SHEET NO. 1	OF 1	SHEETS