

DRAWING FOR REFERENCE ONLY

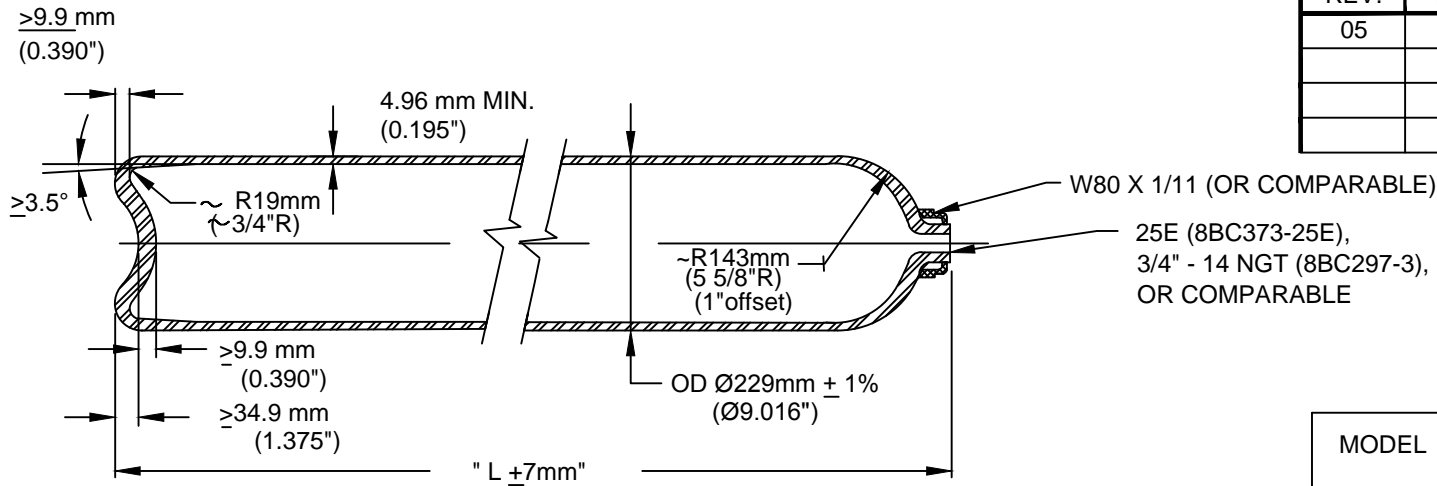

REV.	ECN - DESCIP.	DATE	DRWN.	CHKD.	APP.
05	3130	8/31/12	JJM		

SPECIFICATION: ISO 9809-1: 1999 and ISO 9809-1: 2010	
1. Service Conditions:	
- Working pressure:	200 bar (2900 psi)
- Hydraulic test pressure:	300 bar (4351 psi) <small>(14.5 psi = 1 bar)</small>
2. Material:	
Cr-Mo-steel complying with the requirements of clause 6.2 of ISO 9809-1. Norris' 4137 per Norris Specification EO-A2 is a currently qualified steel.	
3. Manufacture:	
Hot billet extrusion followed by hot drawing	
4. Heat Treatment: Quenched and Tempered	
-Austenitize: ~ 899°C (1650°F)	
-Quenchant: Water based polymer: ~4% concentration (temperature ≤ 60°C(140°F))	
-Temper: ~ 601°C (1115°F) (Min. 30 minutes at temp.)	
5. Mechanical Properties: (at room temperature)	
- Tensile (Rg):	945 - 1075 MPa (137 - 156 ksi)
- Yield (Re):	≥ 803 MPa (116 ksi)
- Elong (A):	≥ 14% (ON 5.65 √S ₀)

5. Mechanical Properties: (continued)	
- Out-of-roundness per ISO 9809-1, 8.5 - <2%	
- Straightness per ISO 9809-1, 8.7- 3 mm per m	
- Verticality per ISO 9809-1, 8.8 -10 mm per m	
- Hydraulic and volumetric expansion test per 11.2	
- Hardness test: Each end of every cylinder HB range: 283 - 322 BHN	
- Flattening test: Flatten to 8 x t _m without cracks	
- Charpy test (-50°C, Trans): ≥ 35 J/cm ² (avg.) ≥ 28 J/cm ² (ind.)	
- UT flaw detection: Each cyld. per ISO 9809-1	
- Batch burst test: Pb ≥ 480 bar (6962psi)	
6(a). Thickness Calculations: (ISO 9809-1)	
$a = 0.5xD \left(1 - \sqrt{\frac{(10FRe - \sqrt{3}Ph)}{(10FRe)}} \right)$	
Where:	
Ph= Test Pressure (bar) = 300 bar (4351psi)	
D = External diameter of container = Ø229 mm Nom	
F = Lesser of 0.65/(Re/Rg) or 0.85; Re/Rg ≤ 0.9	
= Lesser of 0.65/0.85 or 0.85 = 0.765 (for Re/Rg = 0.85)	
$a = 0.5x229.0 \left(1 - \sqrt{\frac{(10x0.765x803 - 3x300)}{(10x0.765x803)}} \right) = 4.95mm (0.1948")$	
NOTE: a', the guaranteed min thickness = 4.96mm (0.1953") equals or exceeds the calculated min thickness, a.	

MODEL	LENGTH 'L'		Min WATER CAPACITY		APPROX. WGT. W/O FITTINGS	
	MM	IN	LITERS	IN ³	KG	LBS
8BC373	1463	57.6	50.0	3051	54.7	120.5
8BC353	1387	54.6	47.2	2880	51.5	113.5
8BC297	1196	47.1	40.0	2441	45.6	100.5
8BC262	1070	42.1	35.0	2136	41.5	91.5
8BC218	917	36.1	30.0	1831	35.6	78.5
*Vmin	698	27.5	20.8	1269	29.5	65
*Vmax	2197	86.5	77	4699	81.6	180

*Note: Model 8BC373 is the design qualification test cylinder. Vmin and Vmax represent the range covered by the same design family.

 NORRIS CYLINDER COMPANY 4818 WEST LOOP 281 LONGVIEW, TEXAS 75603 USA			
REFILLABLE SEAMLESS STEEL CYLINDER FOR COMPRESSED GASES PER ISO 11114-1			
SCALE	NOT TO SCALE	DRAWING NO.	
DWN. BY	R.S.	7/5/06	901A-A-9687
CHK'D BY	F.G	8/22/06	
APP'D BY	R.S.	8/22/06	REV. 05
SHEET NO. 1		OF 1 SHEETS	